

Bi-Fold Plus now suitable for 'Part M' installations

We are delighted to announce that Bi-Fold Plus has met the testing requirements for Part M of the Building Regulations (Access to and Use of Buildings).

By utilising the latest addition to the range of Bi-Fold Plus products, the ultra-low threshold, access has

just become easier for all. Only 24mm tall – far lower than the traditional bulky thresholds offered by other PVC-U bi-fold door suppliers. Available for use with, or without the low threshold tray, both featuring a high quality gold or silver anodised finish, complimenting the hardware.

used for a wide variety of installations, such as an internal room divider for example. Our ultra low threshold is just one of the many innovative design features which makes Bi-Fold Plus stand out and provides fabricators and installers with additional sales opportunities."

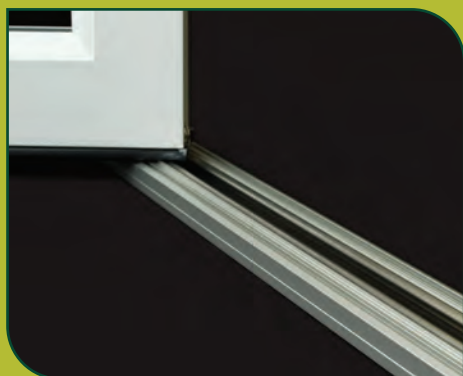

Adrian Redshaw, Liniar's Design Director, comments: "We are delighted our new threshold and tray have passed both initial theoretical and physical ergonomic testing, to be deemed suitable for Part M installations.

Being able to offer unobstructed access means Bi-Fold Plus can be



Liniar's New online WER calculator

To accompany the online U-value calculator, we have been busy behind the scenes creating a new WER calculator. Based on over 2,000 thermal simulations, the new calculator provides accurate indicative Window Energy Ratings for Liniar casement and tilt and turn products.

Available at www.liniar.co.uk the new calculator is easy to use; simply select options from the range of drop-down boxes and you will instantly see the rating that your combination of frame

and glazed unit can achieve. No thermal inserts are required.

The calculator is completely free to use, and you don't need to log on to gain access to it. You can enter as many configurations as you wish until you work out the best combination for your requirements.

Since uploading the calculator we have already added six new residential door styles which now provides a further 192 additional possible profile permutations.

The new calculator is in its early development stages and updates will be implemented throughout the coming months.

Visit www.liniar.co.uk to try it now!



Liniar's Bi-Fold Plus ACES at Wimbledon

Six of the folding sliding doors were recently used in the hospitality area at the famous lawn tennis club, complete with the ultra low threshold and tray.

Coventry based Fabricator Weathershield recently supplied the Liniar Bi-Fold Plus doors after being contacted by the hospitality structures supplier, Arena Structures. They usually use aluminium sliding patio doors but wanted to trial the folding-sliding doors. Having worked with Weathershield before, they called on the Midlands-based company to see how they could help them.

Weathershield's Managing Director Darron Cooke says: "Bi-Fold Plus was ideal for this installation because of its ultra-low threshold. The customer wanted to try the folding sliding doors but needed to be confident that there would be no trip hazards. Bi-Fold Plus is the only range of PVC-U folding-sliding doors that can offer such a low threshold, and by utilising the aluminium tray, this ensured that the whole hospitality area was wheelchair friendly. The feedback we had from the customer has been excellent – even the Championship Director loved them."



Liniar gains PAS 23/24 for French Doors



Liniar's French doors have now achieved PAS 23/24 accreditation at the first attempt.

The doors achieved PAS 23 (General Performance Requirements) and PAS 24 (Enhanced Security Requirements) accreditation during their recent tests at a local UKAS accredited test centre.

The test reports have been submitted to the Secured By Design team, who, at the time of going to press, have given us verbal confirmation that the doors are now added to their list too.

Liniar Showroom

We are pleased to be able to offer the use of our showroom, to demonstrate the Liniar range of quality products to your customers.

At 5,000 ft² and featuring casement, tilt and turn, bay, pivot and French windows, alongside residential, folding/sliding, french and composite doors, plus many other Liniar products.

Please speak with your representative, who can book it on your behalf.



Liniar goes Georgian



We are pleased to advise that we are now stocking the popular clip-on 'Geofast' range from the Georgian Bar Company. The system is suitable for both sculptured and chamfered suites, and is available with the full range of components including the pre-milled endcaps for easy installation.

The system is available in white, cream and a wide range of foiled finishes. The Geofast bars can be used on one or both sides of the window, they simply snap into place via U-clips around the glass, giving a more authentic look than 'in-unit' alternatives.

The system provides a stylish, effective and trouble free answer to anyone wishing to achieve an authentic looking Georgian style double glazed window. The patented Geofast system is quick and easy to apply and is designed to cope with the rigours of onsite installation where necessary, and provides the most authentic Georgian style double glazed window you will ever see.

Latest Liniar Fabrication Manual

If you haven't yet received your copy of the updated Liniar Fabrication Manual, please make your Area Sales Manager aware.

Featuring an additional 22 pages of information on new products, the manual is available in traditional A4 printed and bound format, or on CD.



New products

01/ New Bi-Fold Plus Meeting Stile End Cap

The Bi-Fold Plus Meeting Stile end cap now comes complete with a low threshold adaptor block, which should be assembled as per the illustration, providing a seal receiver in meeting stile/low threshold applications.

Part code: LMO191

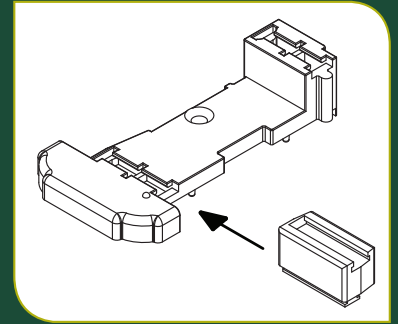

02/ New 44mm Composite Door Transom 'T'

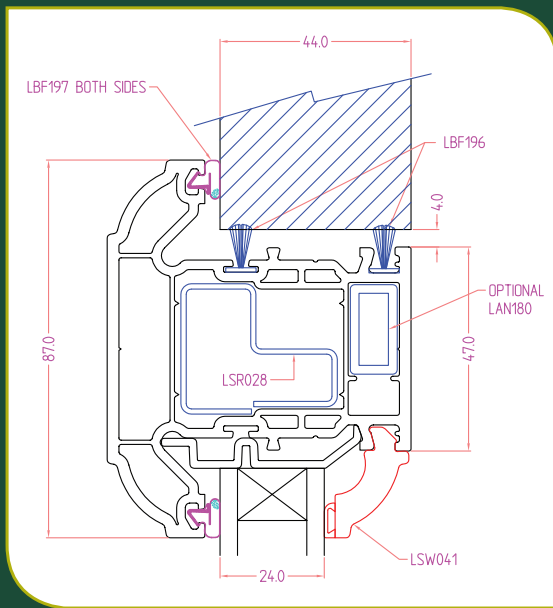

To further enhance the Liniar composite door frame offering, we have introduced a transom T to the range. This will make door/sidelight and door/fanlight combinations that bit slimmer and cost effective.

The symmetrical glazing area accepts a 44mm blank, as well as Liniar standard beads, which can be used to glaze 24mm units (as per illustration). And because it's a symmetrical profile, there is no need to offset.

Lead free and featuring a triple seal arrangement in addition to the Liniar screw retaining pockets for secure hardware fixing.

Part codes:

44mm Composite door Transom T: LSW028W (white): LSW028M (cream-no foil): LSW028BR (rosewood both faces on brown): LSW028CO (oak both faces on caramel): LSW028WW (white foil

both faces on white): LSW028WROF (rosewood large face on white): LSW028WOOF (oak large face on white). White and cream packed in 4 x 6m, all remaining 2 x 6m.

Steel reinforcement: LSR028 single 6m lengths

Brush Pile: LBF196 coils of 200m

Q-Lon LBF197 coils of 300m

03/ New Bi-Fold Plus Low Threshold Sealing

We are pleased to advise that we have introduced two new seals for our best selling ultra low threshold, for the Bi-Fold Plus range of folding-sliding doors.

LBF195 Bi-Fold Plus Low Threshold Seal is to be used on the outside face of the sash bottom rail. Available in black only, in coils of 200m.

LBF198 Bi-Fold Plus Low Threshold Button Strip is used in both grooves of the low threshold to provide enhanced low friction sealing, and an aesthetically pleasing effect.

Available in black only, in coils of 500m.

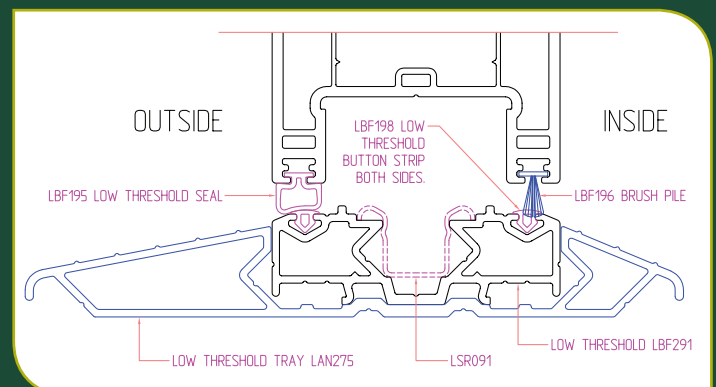

Liniar strengthens its team

In order to support the dynamic growth of the business, we are pleased to welcome a raft of new team members. We would like to take this opportunity to welcome them all and to wish them luck in their new roles.



**John Haywood -
IT Manager**

John joins Liniar with over twenty years of hands-on IT systems, software development and project management experience.

In recent years John has worked as Technical Director for CCS Media then IT Director for Adodo Consultancy Services delivering voice and data solutions to companies large and small. Software that John has designed is in use in a range of well known companies such as Ford, Lloyds-TSB and Liz Earle cosmetics.

**Emma Arrell -
Finance Director**

Emma joined us at the start of 2011 after eight years at NFT Distribution as their Finance Controller. Emma was ready for a career move and when the opportunity to become Finance Director came about, she jumped at the chance. Emma has been busy since joining us and has built up a new Finance team to ensure we continue to grow at a manageable rate, and is putting into place some of best practices learnt throughout her career.



**Louise Pick -
Financial Accountant**

Louise joins us after four years at Delta Rail and brings with her over ten years experience with a broad Financial Accountancy background, including experience of audit and internal controls, budgeting and systems accountancy.



**Mark Cartwright -
Decking and Fencing
National Sales Manager**

Before joining Liniar, Mark was General Manager at Hallmark Sundecks looking after facility, sales and staff management.

Prior to that he was Product Leader at Caterpillar/Perkins Engines covering North America and was responsible for customer account management and supporting the Sales team and Applications Engineers across North America.

Mark is responsible for the East of the UK from Northumberland to Portsmouth - working with existing Installers & Distributors, supporting and encouraging them to grow their businesses. Also Mark will be hunting out potential new Installers & Distributors and encouraging them to come on-board to help us grow our presence and market share.



**Danielle Richards -
Training / Health &
Safety Officer**

Danielle joins us after five years in the industry, and brings with her a wealth of experience of Best Practice for Health & Safety requirements. Danielle has already implemented a new induction programme and procedures for all new starters, and is ensuring that new company policies are being set out in her training programmes.

Danielle is also busy studying for her NEBOSH General certificate - which we wish her the best of luck for.

We would also like to welcome:

Andy Gibson, Paul Windsor, Peter Grundy, Garry Leivers, Sue Gillett and Scott Whittingham to the team and are pleased to announce that Colin Sharpe becomes our new Operations Manager.

Liniar's Lovely Lorries

We are now utilising the ever growing fleet of delivery vehicles to advertise and promote the brand up and down the country. Having recently increased the fleet of transport vehicles by 50%, we are keen to ensure that we have all the tools required to meet, and exceed the demands of our fabricators. From the design and development of the products right through to delivery.



The new additions to the Transport department are all being branded with the Liniar corporate identity, and will showcase a selection of the range of products that Liniar offer, helping to promote the Liniar name to a wider audience.

Liniar's Transport Manager, Paul Fowkes comments: "We understand how important it is to our fabricator's business to receive their deliveries on schedule, so we are investing heavily in new transport to ensure we keep everyone happy. We've had great feedback on the first couple of lorries that have the livery on them, so I'm especially pleased."

Laura Races for Life

Well done to Laura Denyer, our very own Transport Assistant, who recently took part in the Race For Life in Chesterfield in aid of Breast Cancer.

Luckily the weather held out and Laura (pictured right) completed the 5k race in just under 35 minutes and raised just over £200 for the charity.



Well done Laura!

Big Ken's catch of the day



Pictured here is our very own Ken Allen, Area Sales Manager, holding a baby starry eyed smooth hound shark which he caught whilst fishing along the Bristol channel.

Ken couldn't resist sending the photo in as he's promoting the Liniar brand by wearing one of the company t-shirts - Or was it that he didn't want to get his own clothes dirty?!

Thanks for sending it in Ken.

Contact

t.01332 883 900

f.01332 883 901

sales@liniar.co.uk

www.liniar.co.uk



LINIAR WINDOWS, FLAMSTEAD HOUSE, DENBY HALL BUSINESS PARK, DENBY, DERBYSHIRE, DE5 8JX

If you have any news items, interesting installations or stories that you'd like to share, please send them to rosie.cheetham@hlplastics.co.uk